

»XS1

USER MANUAL



TABLE OF CONTENTS

INITIAL SETUP

ACTIVATION STEPS	03
ASSEMBLY & INSTALLATION	03
POWER ON	03
CABLE CALIBRATION	03
CONNECT WIFI	03
FIRST TIME SIGN IN	03

TRAINING

TRAINING CATEGORIES	11
TRAINING ACTIVITIES	11
USING DIGITAL WEIGHT	12
ACTIVE TRAINING SCREENS	13
ADVANCED SETTINGS	15
BEGIN TRAINING	16
ADDITIONAL FUNCTIONALITIES	17

DEVICE OVERVIEW

SAFETY	05
SPECIFICATIONS	05
CONNECTION POINTS	06
USER INTERFACE	06
FORCE PLATES	06
POWER DOWN & SLEEP	06
DECK POSITION	06
BLUETOOTH	07

TRACKING

ACTIVITY & ANALYTICS	20
MOBILE APP	20
ON DEVICE	20
WEB PORTAL	20

ACCESSORIES

STRENGTH ATTACHMENTS	09
CARDIO ATTACHMENTS	09
OXEDOT	09
DIGITAL PILATES	09
BENCHES	09

GAMING

OXEPLAY	22
EXPERIENCES	22
ACHIEVEMENTS	22
LEADERBOARD.....	22
MULTIPLAYER GAMING	23

APPENDIX

IMPORTANT SAFETY INFO	26
REQUIREMENTS	26
MAINTENANCE & CARE	27
SOFTWARE UPDATES	27
WARRANTY	28
LEARN & SUPPORT	28



INITIAL SETUP

INITIAL SETUP

ACTIVATION STEPS

RECEIVE ACTIVATION EMAIL

Close to XS1 delivery date, you will receive an ACTIVATION EMAIL to guide you through a series of activation steps to perform before your XS1 arrives. These steps include creating an account, selecting your membership, and downloading the OxeFit Mobile App. To ensure you have a smooth and easy process setting up your XS1 when it arrives, please complete these activation steps before your delivery date.

CREATE USER ACCOUNT

The link provided in the ACTIVATION EMAIL will direct you to a welcome page connected to your order number. When you are ready to proceed with account creation, follow the prompts.

- Click LET'S BEGIN
- Enter EMAIL ADDRESS
- Enter VERIFICATION CODE sent to email
- Choose USERNAME
- Choose PASSWORD
- Click CONTINUE to proceed with membership selection

IMPORTANT: The username and password used to create an account here will be the same sign-in credentials you will use to access the XS1 device, Mobile App, and OxeFit Web Portal. These can be changed later from your account settings.

SELECT MEMBERSHIP

A one-year OxeFit membership subscription is required to access your XS1. After this initial period, month-to-month membership billing is available. Cancellation and other options are also available.

- Choose from the membership options available
- Click SUBSCRIBE NOW
- Continue with payment to complete order

A confirmation email will be sent to inform you that your membership has been activated.

DOWNLOAD MOBILE APP

You don't have to wait for your XS1 delivery to begin the OxeFit experience. Download the OxeFit Mobile App at any time. An active membership is required to access features and content, but once the activation steps above are complete and you receive the activation confirmation via email, you will have full accessibility to get started with the OxeFit experience right away—even before your XS1 arrives!

- Open the App Store or Play Store on your mobile device
- Search OxeFit → Download App → Open App
- Enter USERNAME & PASSWORD (These will be the same login credentials used to create your account)
- Enter PROFILE INFO (*First name, Last Name, Display Name, and Time Zone*) or select REMIND ME LATER
- Begin exploring OxeFit content

ASSEMBLY & INSTALLATION

No Assembly or installation is required on your end. The XS1 will be fully assembled when delivered to your home or fitness space and will be installed by our technicians. When installation technicians leave your site, they will have:

- ✓ Transported device from delivery truck to location placement
- ✓ Unpacked device
- ✓ Positioned device properly in designated space, with at least 4 in of clearance around all four sides

To complete the initial setup of your XS1, follow the next steps outlined on this page.

POWER ON

- Plug the power cord into a standard three-prong outlet (120 V 15A 60Hz)
- Turn the power switch located on the back of the device to the ON position

SELECT TIME ZONE

- Select GET STARTED
- Select TIME ZONE
- Select CONTINUE

CONNECT WIFI

- Choose WIFI from list of detected networks
- Enter PASSWORD for WiFi access
- Select CONNECT TO INTERNET

FIRST TIME SIGN IN

ORIENTATION ACKNOWLEDGEMENT

Please watch the orientation video and review the OxeFit learning material outlined below. This is for your safety and is required as part of our Terms of Service agreement that governs the use of OxeFit products and memberships.

- Select LEARN ABOUT XS1 to watch the orientation video (7 min)
- Read entire XS1 USER MANUAL before first use
- Read HELP ARTICLES from our support center before first use
- Accept ACKNOWLEDGEMENT or contact support@oxefit.com if you have any questions

LINK USER ACCOUNT

In order to verify your identity, a QR Code will appear on the XS1 screen for you to scan with your mobile phone. This will direct you to the OxeFit portal, prompting you to enter login credentials in order to link your user account to XS1 device. This step must be performed before the first use.

- Enter USERNAME & PASSWORD (same login credentials used to create your account during initial account creation)
- Enter REGISTRATION CODE displayed on XS1 screen

Contact support@oxefit.com if you experience any difficulty.

SET PASSCODE

Follow the on-screen prompts to set up (1) Admin Passcode (2) Device Passcode.

Admin Passcode—4-digit PIN used to change certain Admin/Device settings.

Device Passcode—4-digit PIN used to unlock the screen each time device powers on or wakes from an idle state.



DEVICE OVERVIEW

DEVICE OVERVIEW

SAFETY

Before using the device, please read IMPORTANT SAFETY INFORMATION which can be found as the first section in the APPENDIX. We have prepared this information for your safety. By using the device, you acknowledge that you have read and understand the IMPORTANT SAFETY INFORMATION in its entirety and will adhere to it. Please note that the points below are not intended to represent a complete list of safety guidelines, but rather to highlight a few selected areas of significance.

Only one (1) person is allowed to operate the XS1 at a time. Stay on Deck while performing an exercise. Only use accessories that have been supplied or approved by OxeFit. Keep pets and children away from the XS1.

SPECIFICATIONS

DIMENSIONS

Device w/ Deck Unfolded: 80" L x 45.5" W x 81.5" H
Device w/Deck Folded: 21.5" L x 45.5" W x 81.5" H

WEIGHT

Device Weight: 300 lbs

CABLE RESISTANCE LOAD

Max From Deck: 250 lbs (125 lbs each)
Max From Slides: 140 lbs (70 lbs each)

TECHNOLOGY

Screen: 32" Touchscreen
Connection: WiFi 802.11a/b/g/n/ac
Compatible with MU-MIMO
Sound: Stereo 2x10W

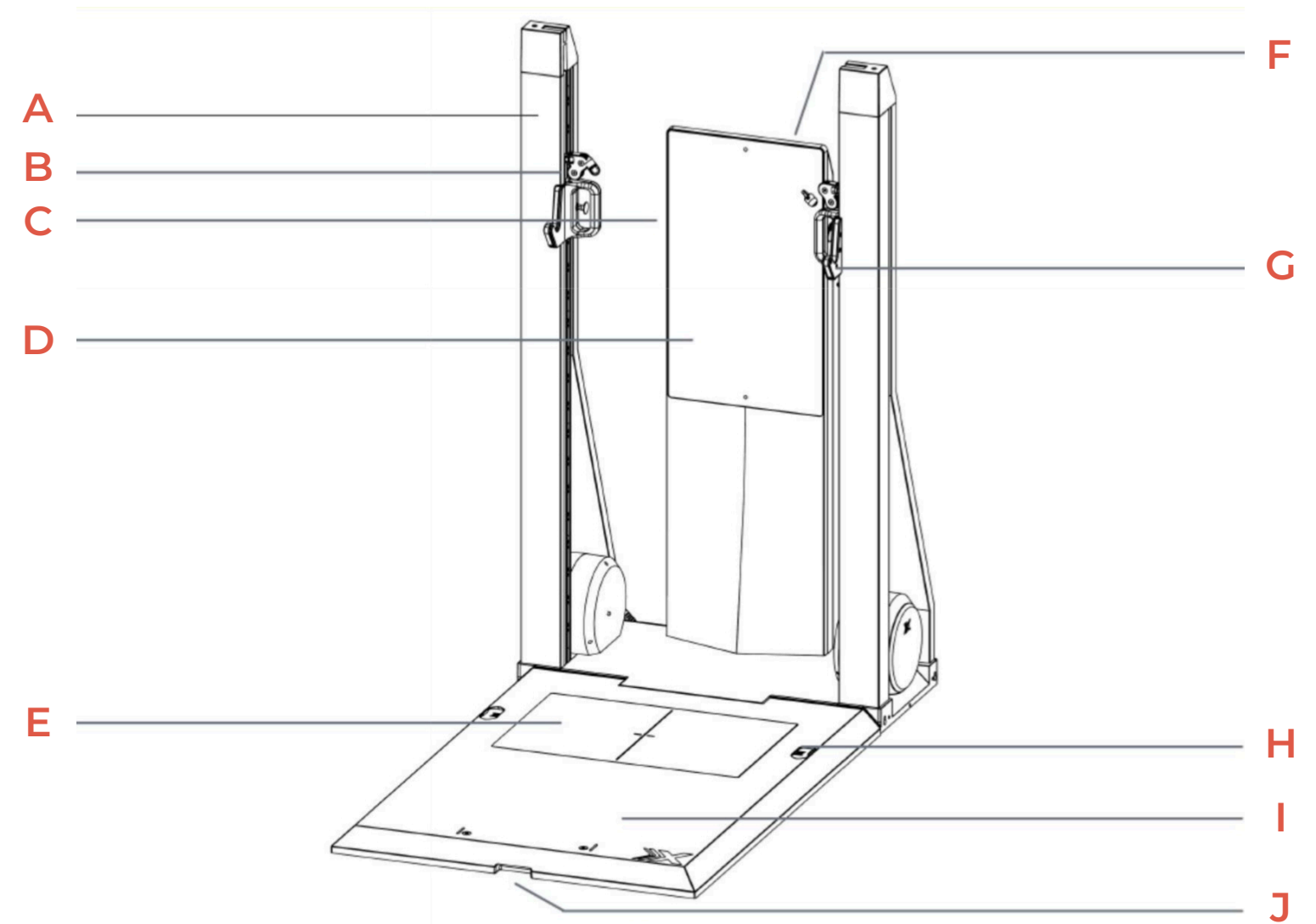

A. Slide Rack

B. Slide Cable Connection (x2)

C. Speaker (x2)

D. User Interface | 32" Touchscreen

E. Force Plate

F. Microphone

G. Slide Handle / Slide Rack Arm (x2)

H. Deck Cable Connection (x2)
Deck Cable Door (x2)

I. Foldable Deck

J. Deck Handle

CONNECTION POINTS

The XS1 has four cable connection points where you can connect accessories and perform exercises from. The first two are slide connections located on the vertical posts, each supporting 70 lbs of digital tension or a combined weight of 140 lbs. **Never adjust the slide positions while the cable tension is loaded.** The remaining two are in the deck, supporting a combined 250 lbs of resistance. The deck connections can be found by sliding open the doors on either side of the force plate.

USER INTERFACE

There are 5 main areas of the user interface. First is the **HOME** section, where you will find featured training content like new releases and special collections. OxeFit trainer profiles are also available here for you to browse and learn more about their classes.

Second is the **GET STARTED** section, where you will find a series of 5-minute video tutorials about using the device. This guidance is for new users and is intended to help fast track the learning curve so you begin enjoying the XS1 fitness experience right away.

Third is **OXEPLAY**, where you can access the fitness gaming experience on the XS1.

Fourth section is **QUICK START**, where you can access an OxeFit library of fitness content, including Exercises, Workouts, Classes, and Programs. Here you will also find Freestyle Mode, which allows you to bypass all the pre-configurations and manually set up the XS1 by selecting the connection point, accessory, advanced settings, and amount of digital cable resistance weight.

Fifth is your **PROFILE**, where you can find all of your tracked activity, fitness progress, workout metrics, and more. Profile is accessed by tapping your user icon.

FORCE PLATE

The force plate is the rectangular inset at the front of the deck. When conducting lifts, such as squats or deadlifts, stand on the force plate with both feet centered and equally spaced. When the balance meter is turned on, you will see real-time feedback of your center of balance to correct your form.

POWER DOWN & SLEEP

ON/OFF button is located at the base of the kiosk. After your training session, there is no need to power down as the XS1 is designed to go into Sleep Mode to protect the screen while remaining available for software upgrades. To start your next workout, simply touch the screen to activate it.

LOCK SCREEN MODE

When the XS1 is powered on but inactive after 4 min (11 min during active training), device will enter lock screen mode. Tap screen anywhere to continue and unlock device with passcode. This will end any in-progress activity.

MOTOR IDLE MODE

After 5 min of inactivity, the cable motors will enter an idle state. The device will begin a pretension sequence when resuming interaction with the screen, force plate, or cables. Stay clear of cables during the pretension sequence.

SCREEN SAVER MODE

When the XS1 is powered on but inactive for 30 min, the device will enter screen saver mode. Tap screen to wake and enter device passcode to unlock and use.

DECK POSITION

When the device is not in use, the deck can fold to a vertical position to save space. If you choose to store the deck in this position, follow the steps outlines below.

NOTE: When folding deck for the first time, two deck straps need to be attached. Hook each deck strap to the round latch point located in between the vertical posts and rear support beams. See image.

NOTE: Two stabilizer legs located under the deck of the XS1 will be visible once the deck is folded up. The stabilizer legs are to remain in place after installation. DO NOT remove or adjust the stabilizer legs. Keep both stabilizer legs fully extended at all times.

NOTE: When folding or unfolding deck, ensure children and pets are clear from area.

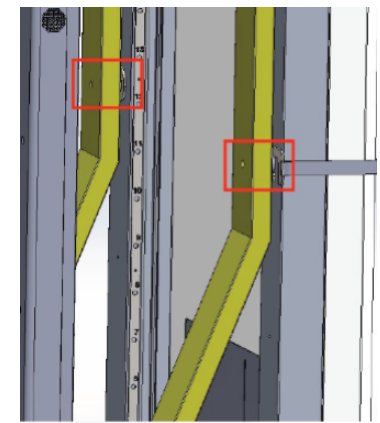

Deck Straps

FOLDING THE DECK

- Disconnect all accessories from the device and remove the bench from the deck.
- Ensure cable tension is unloaded and raise both slide handles to their highest position.
- Close the two deck cable doors.
- Use the handle located at the foot of the deck to raise it up into its vertical position.
- After the deck is folded up against the device, buckle the straps together at the front of the device.

UNFOLDING THE DECK

- Unbuckle the straps at the front of the device.
- Unhook both ends of the deck straps from the latches located in between the rear support beams of the XS1.
- Lower the deck using the deck handle located at the top of the deck.

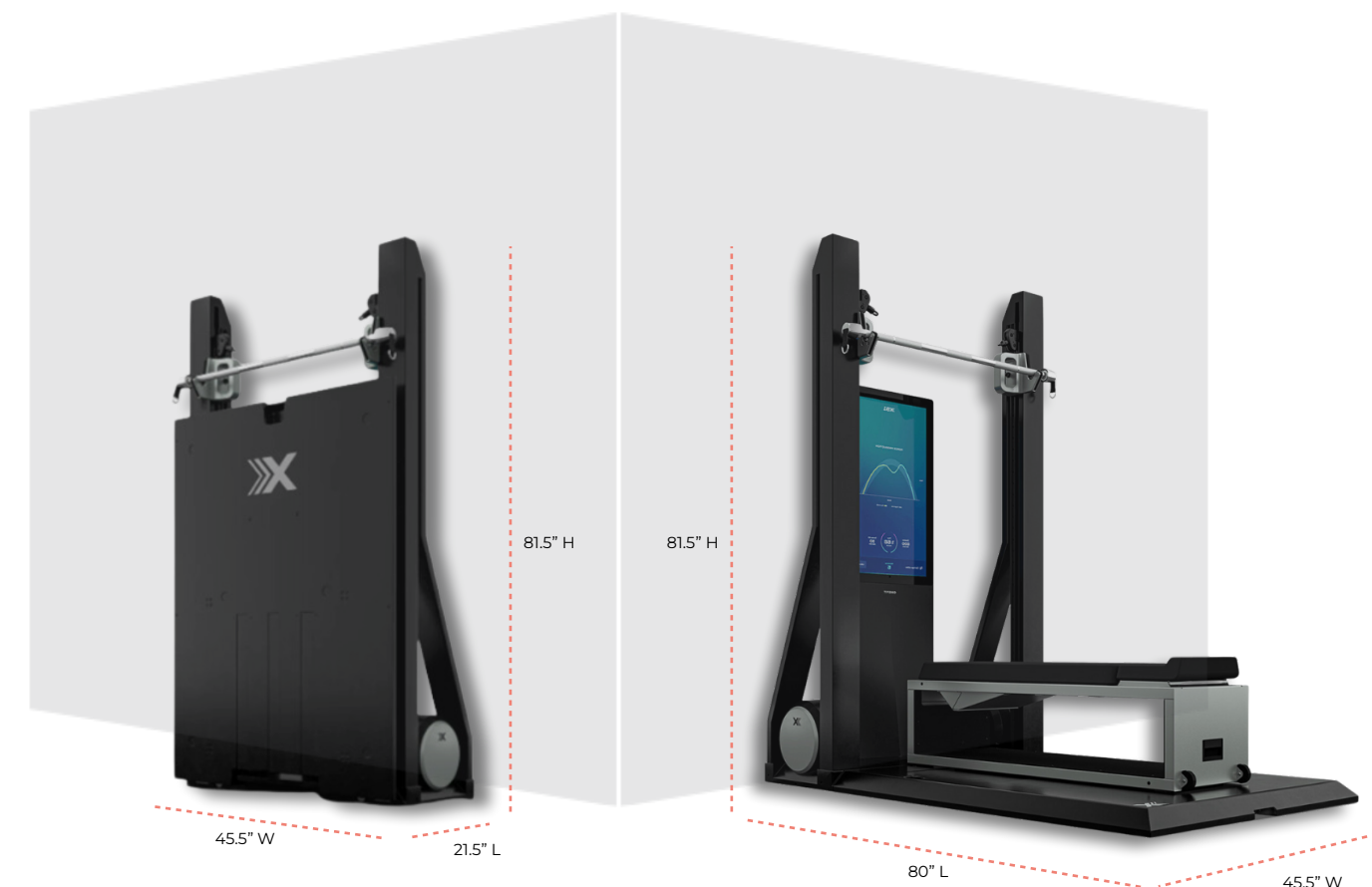

BLUETOOTH

The XSI supports bluetooth pairing for OxeDots, audio devices (headphones/speakers), and heart rate monitors (HRM). Up to three OxeDots can be connected at a time, along with one audio device and one HRM. This functionality allows an active user to have their bluetooth headphones and wearable HRM device paired and in use simultaneously while training, while also using three separate OxeDots, but not multiple audio or multiple HRM devices.

MENU

To access the bluetooth menu, open the toolbar in the top right corner of screen and select Bluetooth. Your bluetooth devices will appear in one of the three sections below.

01. **CONNECTED:** Bluetooth devices currently paired to your XSI.
02. **SAVED:** Bluetooth devices previously paired to your XSI, in conjunction with either your user profile or another's when multi-users share XSI. Devices that are saved by another user will be denoted with the text *Used By Another User*.
03. **SCANNED:** Bluetooth devices nearby in which your XSI has detected a signal for.

Press **CONNECT** next to a device from the SAVED or SCANNED list to pair it.
Press **DISCONNECT** if you want to pair a different audio device.
Press **FORGET** if you want to pair a different HRM.

The current audio device or HRM must be disconnected or forgotten before a different SAVED or SCANNED device of the same type will connect.

All bluetooth devices will only appear in one list at a time—SCANNED, SAVED, or CONNECTED—so connected items will not appear in the SAVED list simultaneously.

There is a filter option to help narrow down the *type* of device you want to see when there are many bluetooth items nearby. Filter for a certain type of bluetooth device—OxeDot, Headphones, HRM—by selecting its icon near the top of the bluetooth menu to make only that device type visible in the CONNECTED, SAVED, and SCANNED lists.

OXEDOT

Your OxeDots will appear in the bluetooth menu labeled by their four-digit ID code.

To preserve battery life, OxeDots will disconnect when XSI is not in use. Click each OxeDot to wake it before each training session and allow a few seconds for it to connect.

A blinking blue light indicates when an OxeDot is in pairing mode.

Always verify OxeDot connection status before use. When you exit the bluetooth menu, the toolbar will display a number next to the OxeDot icon to indicate how many units are currently paired.

When an OxeDot is connected, if you click it, you will see its listing in the CONNECTED section change color. This is useful if you have multiple OxeDots and want to determine which one is which.

See *ACCESSORIES* for how to operate OxeDot.

AUDIO (HEADPHONES / SPEAKERS)

For simplicity, the term *headphones* will be used as shorthand to also encompass any bluetooth audio device that streams a sound, including speakers.

- Place headphones in pairing mode to begin bluetooth connection to XSI (this will be a different step/process for each bluetooth headphones device, so refer to your device's specific user manual for how to do so).
- Open XSI bluetooth menu.
- If needed, use the headphones filter to limit visibility of other device types.
- Allow up to 60 seconds for your headphones to become visible in the XSI bluetooth menu.
- When your headphones appear in the SCANNED list, select the *Connect* button next to it.
- When pairing, you will see the selected bluetooth device move to the SAVED list for just a moment before moving to the CONNECTED list.

- Once connected, the headphones device will be remembered in the SAVED list and will attempt to connect automatically anytime the same user profile is selected.
- Only one audio device can be connected at a time. If you want to connect a different audio device, you must select *Disconnect* next to the one currently in use first before selecting the new one from the SCANNED list.
- Select *Forget* to disassociate any bluetooth device and remove its visibility from your XSI. It will only show up in SCANNED if nearby and in pairing mode.
- The toolbar will display the headphones icon when a device is paired.

HRM

Heart rate monitors (HRM) that use a standard heart rate protocol to broadcast via bluetooth connection can be paired directly to the XSI. See our list of verified HRM devices here: [Connect/Use Heart Rate Monitor](#).

- Place HRM in broadcast mode.
- Open XSI bluetooth menu.
- If needed, use the HRM filter to limit the visibility of other devices.
- Allow up to 60 seconds for your HRM to become visible in the XSI bluetooth menu.
- When your HRM appears in the SCANNED list, select the *Connect* button next to it.
- When pairing, you will see the selected bluetooth device jump to the SAVED list for just a moment before moving to the CONNECTED list.
- Once connected, the HRM device will be remembered in the SAVED list and will attempt to connect automatically anytime the same user profile is selected.
- Only one HRM device can be connected at a time. If you want to connect a different HRM device, you must select *Forget* to disassociate the one currently in use first before selecting the new one from the SCANNED list.
- The toolbar will display the HRM icon when a device is paired.

USER PROFILE OPERATION

Because different users will typically have their own individual headphones and/or wearable HRM, the SAVED visibility for these types of bluetooth devices will pertain to the current user profile selected. When a user logs into their profile on the XSI, their previously used bluetooth devices will attempt to connect automatically when detected. NOTE: Not all bluetooth devices support the ability to auto-connect via bluetooth, as this feature pertains to the manufacturing.

Any previously used bluetooth devices not detected will remain in the SAVED list. The SAVED list will also reflect any bluetooth devices previously paired under another user's profile, such as a family member's, when the XSI device is shared by multiple users. With the exception of OxeDots, users can only *Forget* bluetooth devices that have been paired under their user profile.

MULTI-USER OPERATION

For work-in mode and team workouts, where multiple people are training together in rotation on the XSI, the connected bluetooth devices will also switch depending on the current user profile selected.

If all users in work-in mode each have their own bluetooth headphones, only one pair—the active user's pair—will be connected to receive audio at a time. The same also applies to HRM when multiple active users are training in rotation. When switching user profiles, please allow several seconds for the selected user's bluetooth devices to connect.

BATTERY LEVEL INDICATION

Some bluetooth devices have a battery level indicator that will display how fully charged or depleted it is. Please note that this is a built-in feature solely dependent on your specific device and how it was manufactured. You may see this battery level on the XSI screen for some of your devices, but not all of them, and this is normal. If you believe the battery percentage represented is inaccurate, please contact your bluetooth device's manufacturer.

TROUBLESHOOTING

If you experience any lagging or difficulty, please check with your device's specific user manual or manufacturer for auto connection and timeout behavior. Some bluetooth devices do not support auto connection, as this is a manufacturing feature. When this is the case, simply go to the bluetooth menu and click *Connect* each time.



ACCESSORIES

ACCESSORIES

ACCESSORIES | STRENGTH

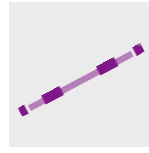

STANDARD BARBELL

14 lbs | Deck Connection | All Barbell Exercises
Bench Press, Squat, Deadlift, Curl, Shoulder Press, & More



HIGH PERFORMANCE BARBELL

45 lbs | Deck Connection | All Barbell Exercises
Increases Max Deck Resistance from 250 lbs to 280 lbs.

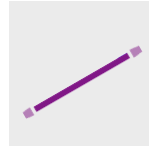

MULTIFUNCTION BAR

Slide Connection | Upper Body & Cardio
Lat Pulldown, Seated Row, Tricep Pushdown, Standing Chest Press, & More



HANDLES

Deck or Slide | Upper & Lower Body
Chest Fly, Curl, Split Squat, Lateral Raise, Lat Pulldown, Seated Row, & More

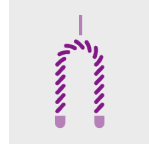

ROPE

Deck or Slide | Upper & Lower Body
Tricep Ext., Front Squat, Hammer Curl, Upright Row, Kneeling Crunch, & More



ANKLE STRAPS

Slide Connection | Lower Body
Hip Ext., Hip Abduction, Hip Adduction, Hip Flexion, Hamstring Curl, & More

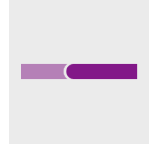

WAIST HARNESS

Deck or Slide | Lower Body
Squat, Lunge, Hip Thrust, Weighted Jump, Calf Raises, Lateral Shuffle, & More

ACCESSORIES | CARDIO



SKIHANDLES

Slide Connection | SkiCross



SINGLE-SIDE PADDLE

Slide Connection | Canoeing & Paddleboarding

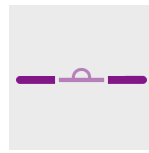

ROW BAR

Slide Connection | Rowing



SURFSWIM PADDLES

Slide Connection | SurfSwim



MULTIFUNCTION BAR

Slide Connection | Kayaking

*Same accessory also used/listed for STRENGTH.

ACCESSORIES | OXEDOT



OXEDOT

A wireless control device that can be used to LOAD and UNLOAD the cable tension during training.

It functions as an alternative option to pressing LOAD and UNLOAD on the UI. Attach the OxeDot to any OxeFit accessory that has an OxeDot Mount. Make sure the OxeDot is positioned where you can easily and safely press the button on it to begin and end your activity. The XS1 can pair with up to 3 OxeDots at a time.

POWER ON

Click OxeDot to "wake" before each training session and allow a few seconds for XS1 to detect its bluetooth signal.

CONNECT

If OxeDot has previously been connected to XS1, it should reconnect automatically. If OxeDot is being connected to XS1 for the first time, it will appear in the Bluetooth Menu under the SCANNED list. When OxeDot appears here, select CONNECT to pair it with XS1. When pairing is successful, OxeDot will move from SCANNED devices to CONNECTED devices in the Bluetooth Menu.

LOAD CABLE TENSION

Press and hold the OxeDot for at least one second (long press) to LOAD the cable tension when ready to begin a set. Make sure you are in position and prepared for the cable(s) to load the selected weight.

UNLOAD CABLE TENSION

Press the button again (short press) to UNLOAD the cable tension when set has been complete.

QR CODE: OxeDot Accessory Guide



ACCESSORIES | PILATES

BASE



CARRIAGE



MAT



BALANCE BAR



TRI-LOOPS



BALL

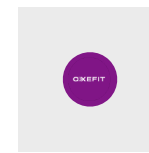

QR CODE: Digital Pilates Assembly Guide



ACCESSORIES | BENCHES



STRENGTH BENCH

41.3" L x 19" W x 17.7" H
Standard flat bench used for STRENGTH training exercises.

MOVE STRENGTH BENCH ON/OFF DECK

- The strength bench has a lightweight design that allows it to be moved on/off deck quickly and easily. Only certain training exercises are performed with the strength bench.
- Position bench fully on deck where both front and back portions are completely stable. Exact bench position on deck will vary and should be adjusted according to exercise.
- Center bench on deck using the two vertical line indicators near the foot of deck.
- Keep Strength Bench off deck when not in use.



MULTIFUNCTION BENCH

53" L x 16" W x 15" H
Adjustable bench used for STRENGTH, CARDIO, & PILATES training exercises.

The longer portion of the MultiFunction Bench is called the *strength pad* and the shorter portion is called the *seat*.

MOVE MULTIFUNCTION BENCH ON/OFF DECK

- **NOTE:** Position of bench may need to be adjusted for different exercises and users. See *Tutorials* on UI for video instructions.
- Remove the two flathead hex screws located at the end of the foot of the deck with a 5/16 Allen wrench.
- Use handle on the end of bench to lift it off the ground and roll it onto deck. The *strength pad* end should be closest to the UI. Position the bench so that it is aligned with the two lines marked on the deck.
- Lock the bench in place by screwing the two center knobs located in between the top and bottom portions of the bench into the two holes that are near the deck markers.
- Deploy the rear kickstand by pressing either the left or right foot pedal out and away from the bench.
- To move the multifunction bench off the deck, lift the handle on one end until the wheels engage, and then roll off.

ADJUST MULTIFUNCTION BENCH FOR CARDIO (ROWING, CANOEING, KAYAKING)

- Remove the *strength pad* and set aside.
- The *seat* can be adjusted to a fixed position **or** remain free to slide during movement, depending on the exercise. To adjust the seat, lift and rotate the knob 90° in either direction until it unlocks in the upright position. Slide the seat to the desired position and use the knob to lock back into the downward position **or** keep knob unlocked and allow seat to slide during training activity.
- To access the foot stirrups, swing the footplate up and lock it into place by rotating the large knob until tight. The footplate also has two open brackets to hold the row bar in place so you can easily reach it when it is connected to the slide cables.



TRAINING

TRAINING CATEGORIES

STRENGTH

Training centered around weightlifting movements which are performed on the XS1 through cable resistance based on digital weight.

There are over 250 strength training exercises to perform on the XS1. The UI allows you to easily adjust the digital weight as needed in between sets. You have the ability to increase or decrease the weight by as little as 1 lb increments, and this is a major advantage compared to lifting with free weights, like dumbbells and barbells where the lowest weight adjustment you can typically make is in 5 lb increments, and the same applies to nearly all other type of weightlifting equipment, like the cable machines you will find in most gyms.

CARDIO

Training centered around cardiovascular intensity in which the *activity* itself is modeled after real outdoor adventures and the movements that would be performed. This is the next level of cardio fitness that enables you to train better specifically for life's adventures.



SkiCross ⇒ Training activity designed to mimic skiing



Rowing ⇒ Training activity designed to mimic competitive rowing



Kayaking ⇒ Training designed to mimic a kayaking adventure



Canoeing ⇒ Training activity designed to mimic canoeing down a river



Paddleboard ⇒ Training activity designed to mimic standup paddleboarding



SurfSwim ⇒ Training activity designed to mimic swimming/paddling on a surfboard

DIGITAL PILATES

Training centered around specific movements and performing them at a controlled pace, all of which is geared towards improving full-body flexibility and stability, especially in the torso muscles of the lower back and abdomen.

SPECIAL INTEREST

A miscellaneous collection of trainings that are centered around a variety of specialized interests. Examples include boxing, MMA, and other classes.

TRAINING ACTIVITIES

EXERCISES

An *EXERCISE* is the individual lift you perform with a sequence (or set) of repetitions (or reps) by which a specific movement is repeated. You perform *reps* within a *set* and *sets* within an *exercise*. Exercises also include the six individual cardio activities.

Access the exercise library to explore the 250+ preset exercises. You can easily navigate all of the options with either the filter tool or search box. Use the filter tool to sort exercises by category, muscle group, accessory, and other options. To find a specific exercise, use the search box.

WORKOUTS

A *WORKOUT* is comprised of multiple exercises performed together. This term will most commonly refer to the section of pre-built workouts available in the content library, which are self-led but guided for you in terms of pre-established exercises, sets, and reps to complete.

CUSTOM workouts are the workouts you have built. See *CREATE TRAINING ROUTINES* on pg. 16

CLASSES

A *CLASS* is a workout that is trainer-led. OxeFit personal trainers release new classes monthly, meaning there is always something fresh for you to dive into. In addition to the STRENGTH, CARDIO, PILATES, and SPECIAL INTERESTS training categories, there are additional types of classes that pertain to a certain style or more dynamical approach in fitness. Below are some of the different types of classes you will find:

WARMUP—5 to 10 minute routines that involve stretching and other movements and are designed to be performed *before* your regular training routine.

COOLDOWN—5 to 10 minute routines that involve stretching and other movements and are designed to be performed *after* your regular training routine.

HYBRID—Routines that involve both *strength* and *cardio* exercises.

COLLECTIONS—Routines designed and curated together under a certain theme.

PROGRAMS

A *PROGRAM* is trainer-led and includes multiple class sessions to complete over an extended duration of time. A recommended schedule is included with each program to help you stay on track towards your goals, but there are no timeframe requirements in which you have to complete the program. Program durations vary, but most will typically take several days or weeks to complete, depending on your frequency. You can only be enrolled in one program at a time. If you have a program in process but want to join a new program, you have the option to either pause or end your current program in order to join the new one. Programs are unavailable to kiosk guest users.

FREESTYLE

You have the option to bypass the pre-built configurations and guidance by selecting **FREESTYLE** mode. Simply choose the connection point on the UI, attach the accessory, and set the weight accordingly. You determine how many sets/reps to complete for strength training **or** the distance/duration to complete for cardio training.

USING DIGITAL WEIGHT

Free weights and other cable machines require the force of gravity to generate resistance. You train by moving weighted plates in the opposite direction. The X51 uses hyper-advanced technology to calculate that same resistance through cable tension. This is often referred to as cable resistance or digital weight. It may not feel exactly the same as free weights, but this is to be expected because the resisting force is being generated differently.

Tension is not applied to the cables at all times. The cable tension is either LOADED or UNLOADED. It remains *unloaded* the majority of the time and is only *loaded* when you manually select for it to be right before each set.

Controlling the weight is done from the user interface.

—— **PHASE 01** —— Before loading the cable tension to begin training, there are three initial setup steps to take: *Select Training—Adjust Cable Position—Attach Accessory*.

SELECT TRAINING

On the UI, select the training activity you would like to perform and determine which cables will be used, either the Slide Cable(s) or Deck Cable(s).

ADJUST CABLE POSITION

When using Deck Cables, no adjustment is needed. Proceed to the next step.

When using Slide Cables, the vertical position of the slide handles must be adjusted according to the training exercise (and possibly your height).

- Firmly grasp slide handle and pull spring-loaded pin knob to release.
- Carefully glide slide handle up or down to desired position while holding the pull pin out.
- Release the pull pin to lock the handle in place.

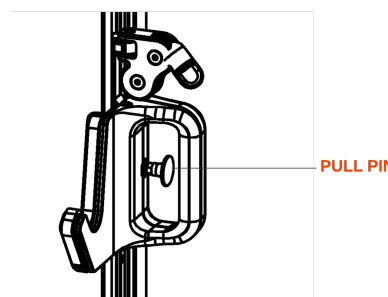

CAUTION: Before beginning an exercise, ensure that the pull pin is fully engaged in a locking hole. Verify proper engagement by ensuring that the orange band located at the base of the pin is not visible. If the orange band is visible, adjust the slide slightly up and down until the pin is fully engaged. Never adjust the Slide Handle position while weight is loaded and an exercise is in progress. Always press Unload before adjusting the vertical position of the slide. Never start an exercise if the locking pin is not fully engaged.

ATTACH ACCESSORY

- Connect carabiners (clips) to end of cable(s) if not already in place.
- Attach accessory to cable(s) by clipping connection points to carabiners.
- Mount OxeDot to accessory if desired.

—— **PHASE 02** —— To initiate and complete a training exercise or set, there are three main actions to take: *Load Cable Tension—Perform Lift—Unload Cable Tension*.

LOAD CABLE TENSION

No cable tension is applied until you LOAD the weight. Loading the weight applies tension to the cables based on the amount of resistance you have set. To load the weight, select the LOAD button on the UI.

LIFT

After loading the weight, the device is ready for you to begin your training exercise or set. Get into the necessary position on the device, firmly grasp the accessory attached to the cable(s), and perform the training movement until the reps/set or routine is complete (*reps/set* refers to strength training and *routine* refers to cardio training).

UNLOAD CABLE TENSION

Once the set or routine is complete, rack the bar (if necessary) or gently lower the cables all the way to the deck or rack so you can release hold of the accessory. Select UNLOAD on the UI to disengage the cable tension and complete your set.

Different ways to UNLOAD cable tension:

— USER INTERFACE —

Standard method, as stated above.

Select UNLOAD on the UI to disengage the cable tension and complete your set.

— OXEDOT —

Attach clickable OxeDot to accessory and use to load and unload cable tension.

See [Accessories](#) → [OxeDot](#)
See [Device Overview](#) → [Bluetooth Settings](#)

— UNLOAD AT REP COUNT —

TARGET REP COUNT is a feature that allows you to set and easily adjust how many reps you want to achieve within a set.

UNLOAD AT TARGET REP COUNT is an optional function of Target Rep Count that can be selected ON/OFF for each set. When turned ON, the cable tension will automatically unload as soon as the target rep count is reached.

See [Target Rep Count](#) on pg. 18 for complete info.

— SAFETY FEATURES —

The cable tension will unload when certain detections are made.

BAR TILT

The bar rapidly tilts while lifted.

STALL DETECTION

There is no movement at the bottom of your range of motion for 5 seconds or if there is no movement detected for 15 seconds at any portion of a lift.

TRAINING

ACTIVE TRAINING SCREENS

REAL-TIME FEEDBACK

Let the Real-Time tracking feedback you see on the UI guide your training sessions. Use the illustrations below to learn how to read the various components of the XSI screen during training.

STRENGTH ACTIVE TRAINING SCREEN

A. Exercise Name
 B. Exercise Set Number
 C. Exercise Timer (Active or Rest)
 D. Repetition Count
 E. Range of Motion Indicator
 F. Advanced Settings Currently Applied
 G. Amount of Weight Currently Loaded
 H. Change Exercise, End Exercise, or End Workout
 I. Average Max Power/Velocity Generated During Set
 J. Real-Time Power/Velocity Output
 → Tap here to toggle view between Power or Velocity
 K. Max Power/Velocity Generated During Rep
 L. Instantaneous Power/Velocity Ring
 → Real-Time Power/Velocity output relative to Max Power/Velocity output generated during set
 M. Cable Connection Point
 N. Decrease Weight
 O. Base Weight Selected
 P. Increase Weight
 Q. LOAD or UNLOAD Weight

WORKOUT SUMMARY

At the end of each training session, a summary of your activity will be displayed on the screen. This information is primarily for your quick reference and is an overview of the more detailed analytics that will be logged in your *Activity History*.

CARDIO ACTIVE TRAINING SCREEN

A. Distance/Duration Progress
 B. Distance/Duration Goal
 C. Power Production
 01. Current Stroke Production
 02. Previous Stroke Production
 D. Elapsed Time
 E. Distance Covered
 F. Pace
 G. Stroke Rate
 H. Average Pace
 I. Instantaneous Pace Ring
 → Real-Time Pace relative to Fastest Pace
 J. Decrease Base Resistance
 K. Base Resistance
 L. Increase Base Resistance
 M. Current Resistance

PILATES ACTIVE TRAINING SCREEN

A. Decrease Spring Tension
 B. Base Spring Tension
 C. Increase Spring Tension
 D. Current Spring Tension

Movement Rhythm Visualization

ACTIVE TRAINING SCREENS continued

POWER/VELOCITY DISPLAY VARIATIONS

Some values on the Active Training Screen may vary between Power vs. Velocity view in conjunction with Single vs. Dual accessory view.

NOTE: These displays only pertain to Strength Exercises.

POWER

SINGLE DISPLAY

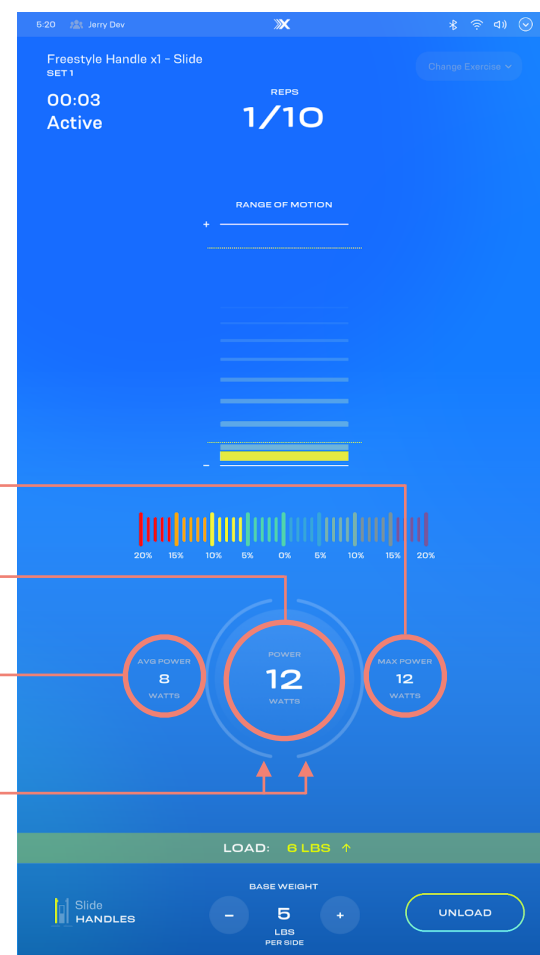

- A. Max For Set
- B. Max For Rep
- C. AVG Max For Set
- D. Instantaneous Power
% Relative to Max

DUAL DISPLAY

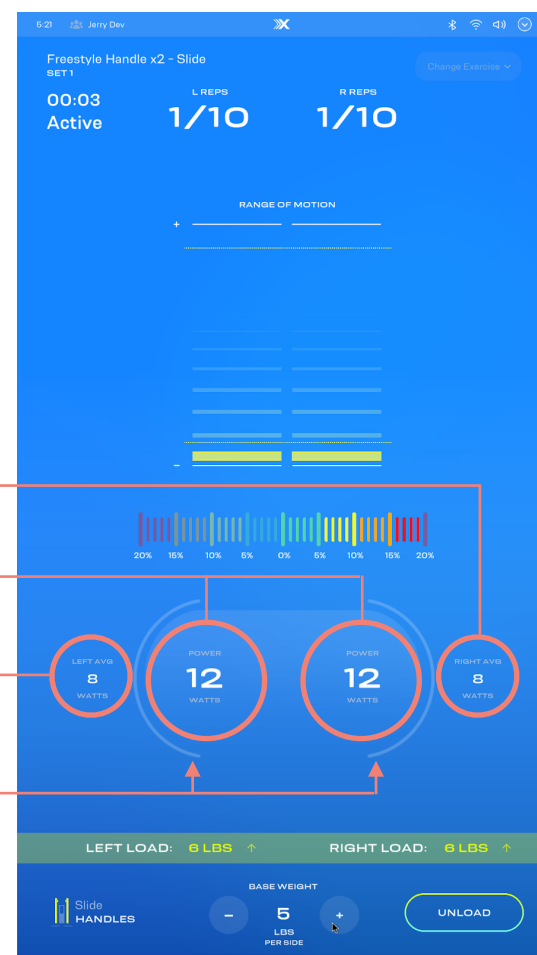

- A. Max For Set (Right)
- B. Max For Rep (Left & Right Side)
- C. Max For Set (Left)
- D. Instantaneous Power (Left & Right Side)
% Relative to Max

VELOCITY

SINGLE DISPLAY

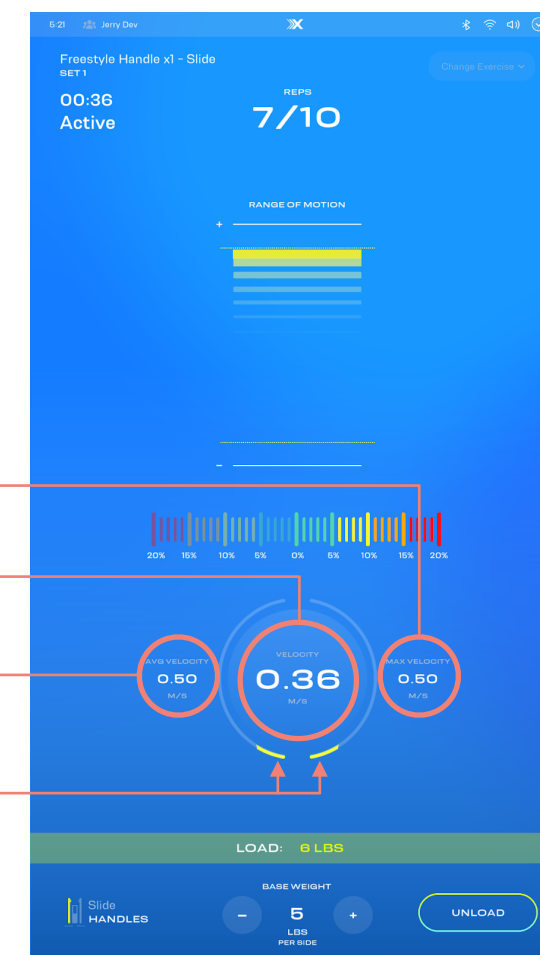

- A. Max For Set
- B. AVG For Rep
- C. AVG For Set
- D. Instantaneous Velocity
% Relative to Max

DUAL DISPLAY

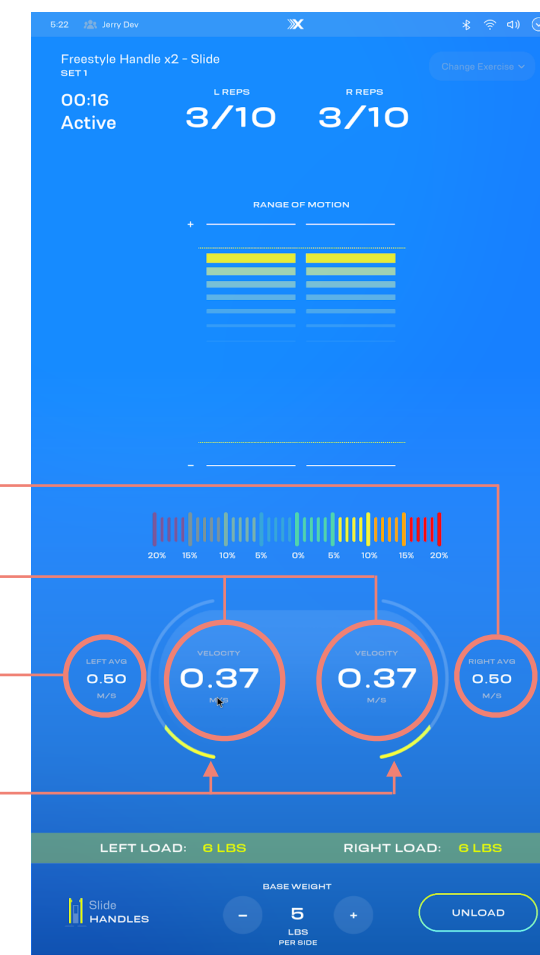

- A. AVG For Set (Right)
- B. AVG For Rep (Left & Right Side)
- C. AVG For Set (Left)
- D. Instantaneous Velocity (Left & Right Side)
% Relative to Max

ADVANCED SETTINGS

Advanced Settings are designed to maximize your training by way of altering the cables to react in specific ways based on the selected setting. Using Advanced Settings helps target your training even more towards a particular “style” or “technique,” based on your personal goals and what you want to achieve.

For pre-configured exercises, access Advanced Settings from the active training screen. For Freestyle exercises, access Advanced Settings when you set up your movement or adjust from the active training screen.

You can change the Advanced Settings within an exercise by unloading the weight and selecting Advanced Settings, located near the lower right side of the active training screen.

NOTE: CONCENTRIC & ECCENTRIC PHASES

A rep has two different phases: the Concentric phase and the Eccentric phase. The Concentric Phase is when you pull the cables out against the resistance of the device or, in traditional weight lifting, raise the weight. The Eccentric Phase is when you release the cables back into the device, or in traditional weight lifting, lower the weight. The concentric weight will apply during the concentric phase of your motion. The eccentric weight will apply during the eccentric phase of your motion.

ADVANCED SETTINGS | CARDIO

INTERVAL

The resistance will alternate between the working resistance and the base resistance based on the interval duration you set.

BEGINNER (1:2): The duration of the working resistance will be half the duration of the base resistance.

INTERMEDIATE (1:1): The duration of the working resistance will be equal to the duration of the base resistance.

ADVANCED (2:1): The duration of the working resistance will be double the duration of the base resistance.

HILL

The resistance will gradually increase from the base resistance (bottom of the hill) to the peak resistance (top of the hill) over the course of your working interval and then reset back to the base resistance as soon as you reach the peak.

DISTANCE

Set a target distance for your exercise and the resistance will automatically unload when that span has been reached, ending your exercise.

DURATION

Set a target duration for your exercise and the resistance will automatically unload when that time has elapsed, ending your exercise.

ADVANCED SETTINGS | STRENGTH

VIRTUAL SPOTTER

The load will gradually or instantly decrease when a struggle is detected, based on the mode selected: *Gradual Return*, *Gradual Reduce*, *Instant*.

GRADUAL RETURN: The load will gradually decrease when assistance is needed to complete the concentric phase of a rep and will then *Return* to the full amount once the rep is complete.

GRADUAL REDUCE: The load will gradually decrease when assistance is needed to complete the concentric phase of a rep and will then remain at the *Reduced* amount for the next rep.

INSTANT: The resistance will be unloaded completely when you are unable to complete the concentric phase of the rep.

This training method is designed to maximize your load capacity by allowing you to safely attempt heavier loads and/or more reps during a lift than you'd typically be capable of.

BURNOUT

The load will increase or decrease with each consecutive rep in a set, depending on your selection.

INCREASE: Set an additional load amount to be added incrementally after each rep.

DECREASE: Set a load amount to be subtracted incrementally after each rep.

This training method is designed to increase your overall muscle hypertrophy, including size, stamina, and motor unit recruitment.

CHAINS

The load will increase or decrease throughout the range of motion, depending on your selection

REGULAR: The load will increase throughout the concentric phase and decrease throughout the eccentric phase, with the full chain weight applied at the “top” of your range of motion. This training method is designed to increase your explosive power.

INVERTED: The load will decrease throughout the concentric phase and increase throughout the eccentric phase, with the full chain weight applied at the “bottom” of your range of motion. This training method is designed to maximize your force output during the onset of each concentric phase.

OVERLOAD

The load will increase during the selected phase of each rep by setting the percent overload.

ECCENTRIC OVERLOAD: Because you can resist a greater force than you can generate, setting heavier eccentric weight is an effective strength building method. This training method is designed to stimulate greater muscle growth, improve joint stability, and decrease risk of injury.

CONCENTRIC OVERLOAD: Setting heavier concentric weight allows you to conserve more energy during the eccentric motion so you can generate more concentric force. This training method is designed to maximize load capacity and power output.

A.I. ADAPTIVE

The load will increase with each rep until your motion indicates a struggle, gauged by the target average concentric speed you set.

The goal is to perform each rep with a smooth and consistent speed in order to find your “Optimal Load,” which is the amount that you can complete 10 reps of with moderate effort.

Set the target average concentric speed based on the specific exercise movement, for example ones that are more explosive should have higher target speeds.

This training method is designed to determine your optimal load based on your concentric phase velocity.

REACTIVE

The load will increase or decrease based on the previous rep's average concentric velocity in order to help you maintain a consistent target speed.

This training method is designed to maximize the concentric load you can move with a certain velocity.

PERTURBATION

The cables will receive randomized oscillations throughout the range of motion that disrupt your balance and force your body to react.

This training method is designed to improve the body's ability to react and stabilize effectively, enhancing overall strength, coordination, core activation, and injury prevention.

BALANCE

The force plate will measure weight distribution when conducting lifts and will display a balance meter on the screen to provide real-time visual feedback of any asymmetries in your balance.

TRAINING

BEGIN TRAINING

Provided here is a start-to-finish walkthrough of how to begin a training routine on the XSI, broken down into simple steps for easy reference.

01. SELECT TRAINING ACTIVITY

On the UI, select the training activity you would like to perform.

02. ADJUST CABLE POSITION

If using the slide rack, adjust the cables to the proper position according to the exercise.

03. ATTACH ACCESSORY

Connect the necessary accessory to either the slide cables or deck cables.

04. CHOOSE ADVANCED SETTING(S)

If you would like to apply Advanced Setting(s), select them now before engaging the digital weight.

05. LOAD WEIGHT

When you are ready to begin your lift, press the LOAD button on the screen to engage the digital tension on the cables.

06. LIFT WEIGHT

Proceed with your lift, performing all reps you want to complete within the set.

07. UNLOAD WEIGHT

When you have completed your lift, rack the barbell (if necessary) and press the UNLOAD button on the screen to disengage the digital tension on the cables.

08. COMPLETE ALL SETS

Repeat steps 4-7 until all sets in the exercise have been completed.

09. COMPLETE TRAINING ACTIVITY

Select END TRAINING when you have completed all exercises within the current routine.

10. WIPE DOWN ACCESSORIES

Use a disinfectant cleaner and towel to wipe down all accessories used during your training session.

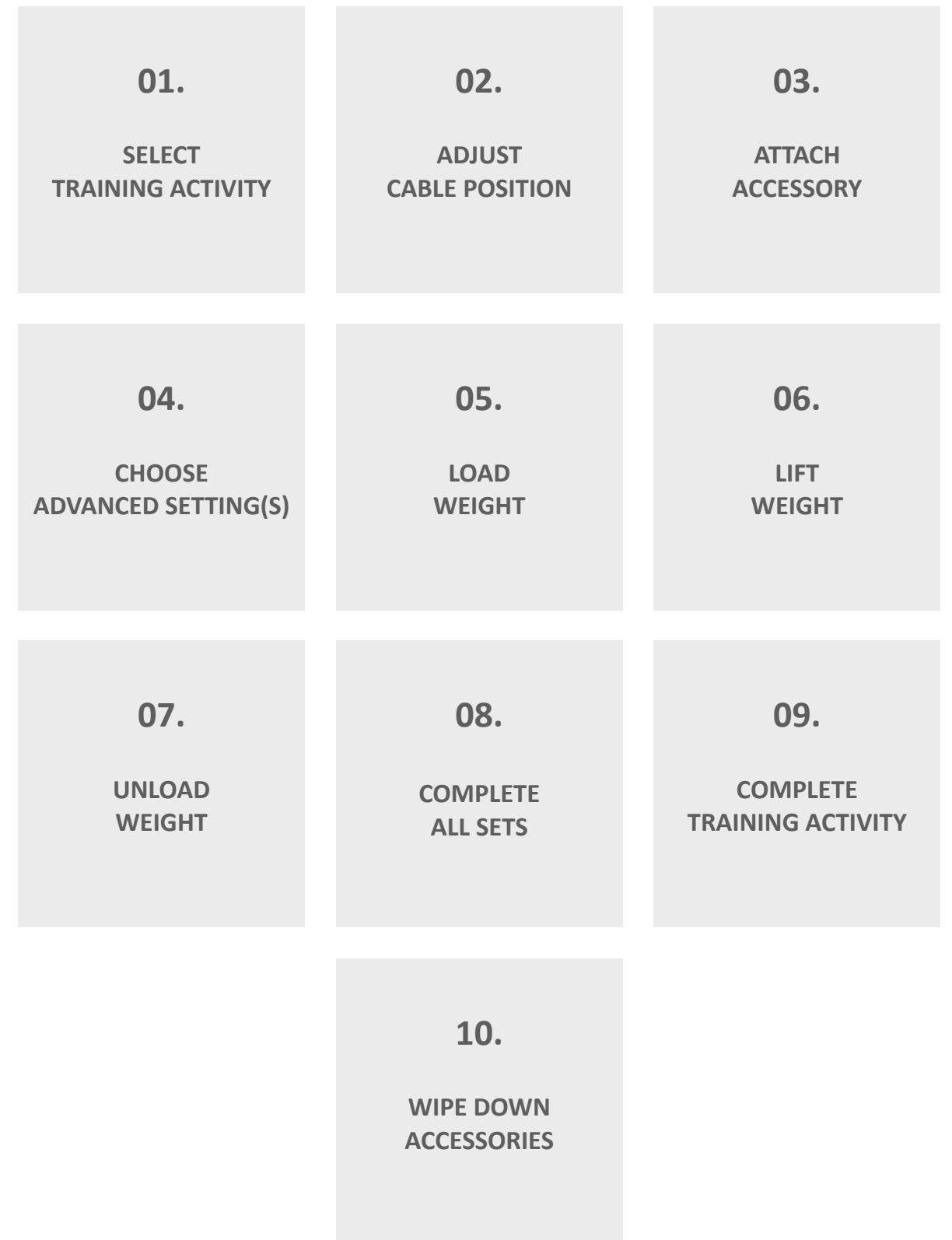

ADDITIONAL FUNCTIONALITIES

BUILD CUSTOM WORKOUTS (MOBILE APP)

1. Open Mobile App and select **EXPLORE** tab.
2. Select **CUSTOM WORKOUT** icon in top right corner.
3. Select **CREATE NEW WORKOUT** icon in bottom right corner.
4. Select **XSI** when asked which platform.
5. Add **WORKOUT TITLE** and any **WORKOUT NOTES** you'd like to include.
6. Add **BLOCKS**
 - **BLOCKS**—are a structural aspect that allow you to group exercises within your workout in various ways. You can add as many **BLOCKS** as you need and rename each one.
7. Add **EXERCISES**
 - **EXERCISES**—are added within each Block. Select the individual exercises you want to add.
8. Configure **EXERCISE SETTINGS**
 - **EXERCISE SETTINGS**—adjust number of Sets, Reps, and Advanced Settings to customize each exercise you include.
9. Choose **ROUND ON/OFF**
 - **ROUND**—is an optional function that pertains to the workout structure of each Block. It allows you to perform alternating sets of each exercise within a Block.
 - **ROUND OFF**—when turned OFF, the Block remains defaulted to **STANDALONE**
 - **ROUND ON**—when turns ON, the Block will automatically become:
 - **SUPERSET** when 2 exercises are present
 - **TRISET** when 3 exercises are present
 - **CIRCUIT** when 4 or more exercises are present
10. Continue adding **BLOCKS** and **EXERCISES** and configuring settings to build out your workout.
11. Select **SAVE** when complete.
12. The Custom Workouts you create will appear on your XSI, under the **FEATURED** tab.

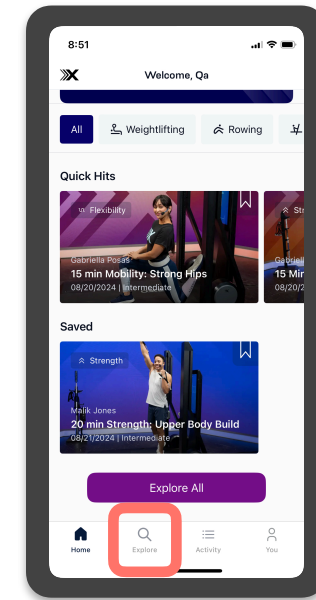

1 EXPLORE tab

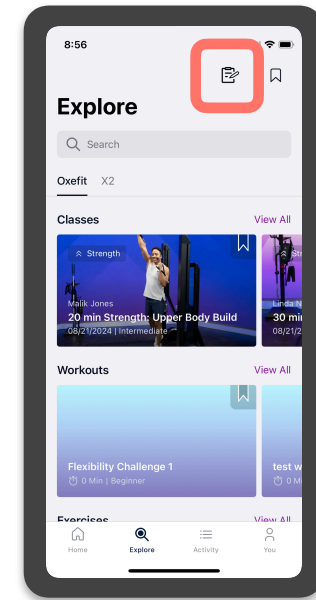

2 CUSTOM WORKOUT icon

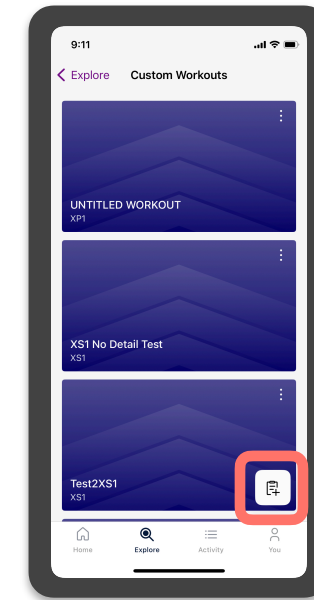

3 CREATE NEW WORKOUT icon

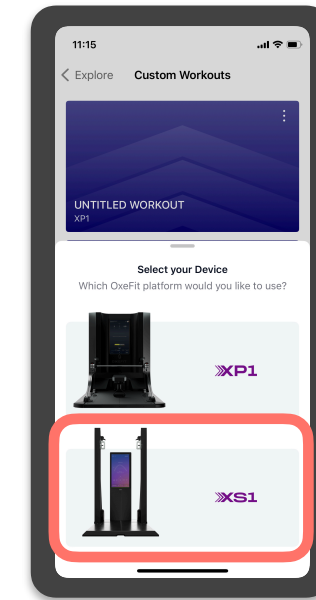

4 XSI platform

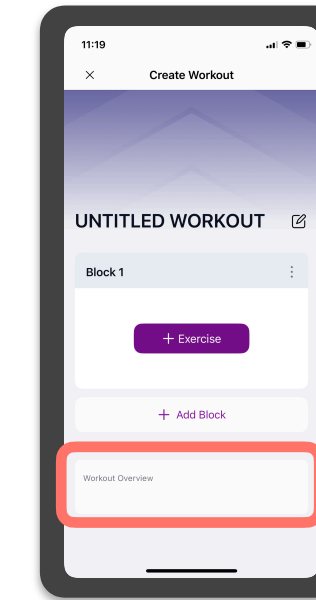

5 WORKOUT TITLE & NOTES

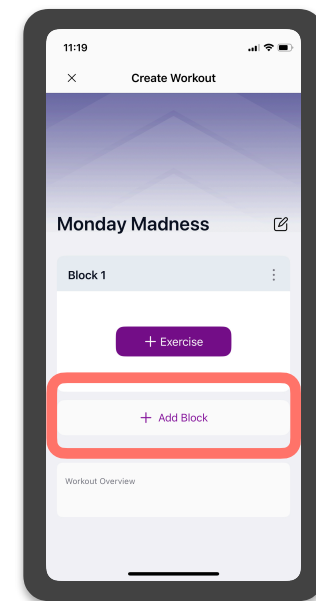

6 Add BLOCKS

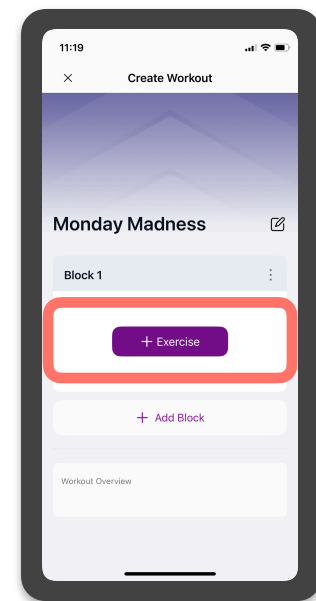

7 Add EXERCISES

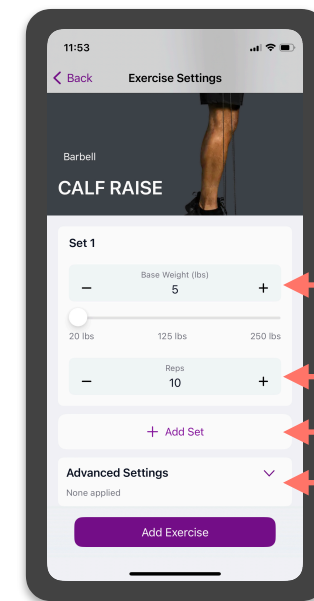

8 Configure EXERCISES SETTINGS

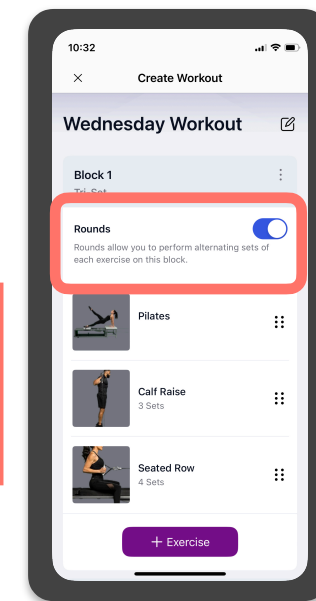

9 Choose ROUND ON/OFF

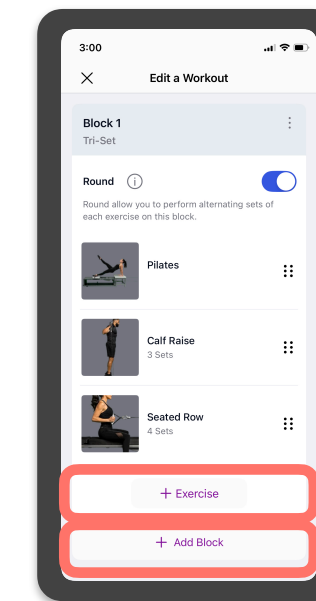

10 Continue adding BLOCKS & EXERCISES

ADDITIONAL FUNCTIONALITIES continued

BOOKMARK TRAINING CONTENT (MOBILE APP)

Explore the content library and bookmark any trainings you want added to your SAVED list.

- Open Mobile App and go to **Explore** tab.
- Browse training content.
- Open any **Workout** or **Class** to preview.
- Select the **Bookmark Icon** to add item to SAVED list.
- Access **Saved** list via the **You** tab (Mobile App) or via **Profile** tab (XS1 device).

SCHEDULE TRAINING SESSIONS (MOBILE APP)

Add workouts and classes to your calendar. The training routines you schedule will appear on your Mobile App's HOME Screen and on your XS1 device under the WORKOUTS tab.

- Open Mobile App and select **Explore** tab.
- Select the **Workouts** or **Classes** tab from the top menu.
- Find & Select the training routine you intend to schedule.
- Press the **Schedule** button.
- Select the **Calendar Date**
- Two options:
 - **Once**—schedule a single occurrence or select
 - **Repeating**—schedule a recurring event on the same selected day(s) each week.
- Press **Schedule** when complete to add training routine to calendar.

WORK-IN MODE (ON DEVICE)

Enabling this feature allows multiple users to train together with rotating sets throughout a routine.

Work-In Mode can be selected ON/OFF from the user icon located top-left of screen. Choose ADD USER or ADD GUEST to include additional participants.

Switching back and forth between users during training is quick and easy. Before each set, the active user simply needs to select their profile from the Work-In Mode drop down menu (user icon, top-left of screen).

In order for the XS1 to accurately track and group each user's activity together, make sure the correct user profile is selected before each set.

Work-In Mode is available in conjunction with the following training activities:
Freestyle | Workouts | Classes | Programs

TARGET REP COUNT (ON DEVICE)

TARGET REP COUNT is a feature that allows you to set and easily adjust how many reps you want to achieve before each set. A notification sound then chimes during exercise to inform you when target rep count is reached

UNLOAD AT TARGET REP COUNT is an additional function that can be selected ON/OFF for each set. When turned ON, the cable tension will automatically unload as soon as the target rep count is reached.

Engaging or disengaging this function can only be done in between sets while the weight is UNLOADED, not while exercise is in progress. In other words, be sure to select ON/OFF before loading the weight to begin each set.

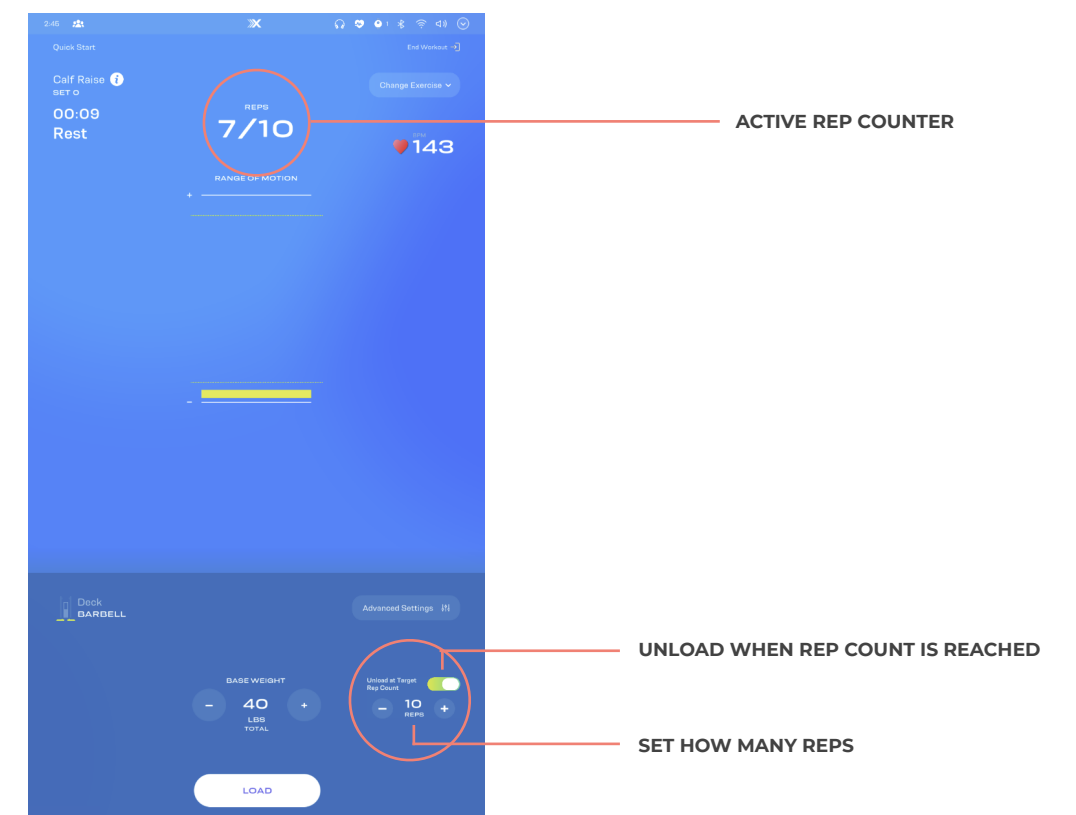



TRACKING

TRACKING

ACTIVITY & ANALYTICS

MOBILE APP



Tracking fitness via the OxeFit Mobile App.

The XSI automatically syncs information to/from your OxeFit Mobile App. This includes your workout schedule, custom workouts you have created, and more. All training activity performed on XSI under your user profile is logged and available to review on the Mobile App once complete.

ON DEVICE



Tracking fitness directly on XSI User Interface.

When actively performing a training activity on the device, the user interface provides real-time tracking information to enhance your experience during training.

Once a training routine is complete (exercise, workout, etc.), the XSI will display a snapshot summary of that routine on the screen. A detailed summary of analytics will be logged in your Activity History and available for review anytime.

WEB PORTAL



Tracking fitness via the OxeFit Web Portal.

If setup, the XSI automatically syncs information to/from your OxeFit Web Portal account. This platform is an alternative option to the Mobile App. Depending on the user activity performed, there may be additional graphs or charts displayed as visual representations of training analytics.



Build Custom Workouts



Schedule Training Sessions



View Activity History



Weekly Progress



Post-Training Analytics



Build Custom Workouts



Schedule Training Sessions



View Activity History



Weekly Progress



Post-Training Analytics



Build Custom Workouts



Schedule Training Sessions



View Activity History



Weekly Progress



Post-Training Analytics



GAMING

GAMING

OXEPLAY

OxePlay is an immersive gaming experience enabling even more ways to take control of your fitness. Train fitness with gamified strategy to complete challenges and other objectives.

The XSI screen becomes the interactive scene of your adventure, and you must paddle, ski, or perform other activities in order to complete the challenge. There may be hazards to avoid along the way, tokens to collect, or other objectives depending on the OxePlay experience you choose.

EXPERIENCES

KAYAKING

Paddle your way across the river to reach the finish line as fast as you can. Collect coins and avoid obstacles as you race against time. And don't let the gators get you!

Choose Track: Morning Mist | Majestic Caves
Desert Sunset | Jungle Ruins

Choose Level: Beginner | Intermediate | Advanced

Choose Kayak: Use color tool to customize your ride



SKIING

This game fully utilizes OxeFit's unique force plate technology, enabling you to steer by shifting your body weight and perform jumps to make your skier launch over fallen trees scattered throughout the course. Race against time, race against a simulation of your best time, or have fun challenging your friends and family.

Choose Track: Flat | Downhill | Hilly | Full Course

Choose Level: Beginner | Intermediate | Advanced



MAZE MADNESS

A classic game remastered with fitness via OxePlay! Navigate the ball through the maze to reach the exit. Shift your bodyweight on the XSI's force plate to tilt the board and control the ball's rolling direction.

Choose World: Forest | Cave | Tundra

Choose Level: 10 levels in each world



Support Article: [Maze Madness](#)

ACHIEVEMENTS

Achievements are awarded when a track (Kayaking, Skiing) is completed with exceptional performance in one of the keynote areas: Strength | Speed | Stamina | Safety

Each area has an established criteria that a performance must reach in order for achievement to be awarded. All previously earned achievements are visible in your *Tracked Activity*.

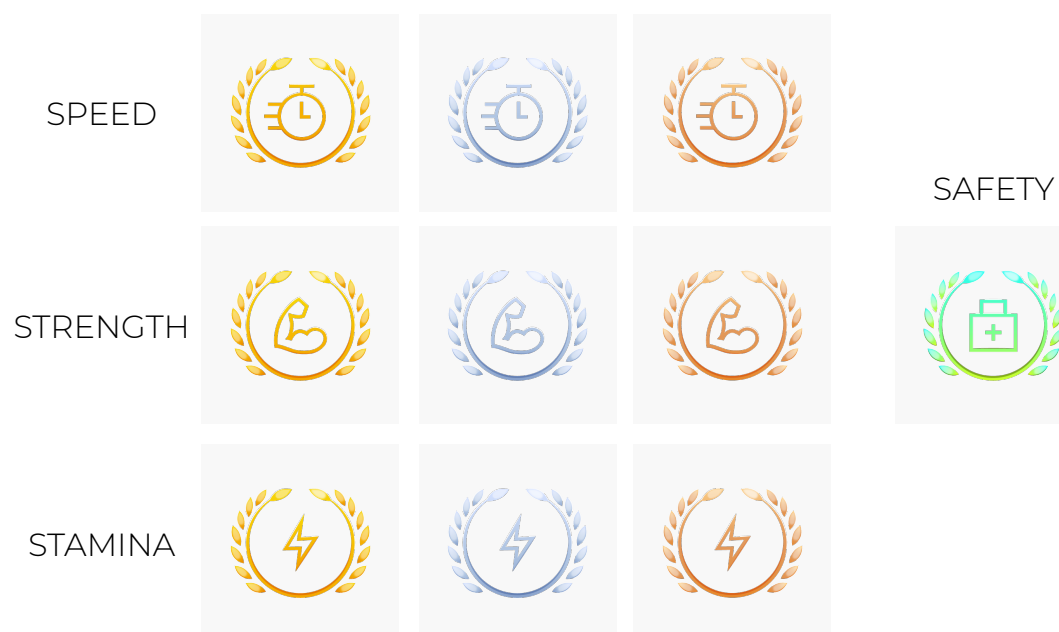

LEADERBOARD

The leaderboard encourages a community-wide spirit of competition among OxeFit gamers. It features the top ranked performances in OxePlay for each of the different tracks and difficulty levels.

NOTE: Users must be signed in to their profile for leaderboard eligibility. If guest mode is used, OxePlay activity will not be logged nor eligible for leaderboard ranking.

FRIENDS & FAMILY

This visibility includes the top ranked performances only from the user accounts associated with your specific XSI device. This may include household family members who share a device and/or friends you allow account access to on your device.

GLOBAL

This visibility includes the top ranked performances from all user accounts within the OxeFit community.

GAMING

MULTIPLAYER GAMING

INTRODUCTION

Compete with others in Oxeplay! Gaming in OxePlay offers multiplayer capability—enabling you to compete in Kayaking and Skiing matches against friends, family, and other OxePlay gamers around the world. Provides a fun and exciting cardio workout in a gaming theme with the added experience of competition.

SPECIFICATIONS

- Each game can include a max of 6 players.
- Multiplayer requires online mode. Offline gaming is NOT supported.
- All participating XS1 devices must have the latest software update version of OxePlay.

MULTIPLAYER MODES

PUBLIC – allows online players to find open game sessions to join with other active players from around the world. Players pool together to start a game, but typically will not know each other.

PRIVATE – allows online players to join a known game by using an invitation code they receive from another player (the Host), who is typically a friend, family member, or someone known.

PLAYER ROLE TYPES

HOST – user who creates the game session (open lobby). Host is in charge of setting up game options (game selection, track, level of difficulty).

GUEST – any user who is NOT the Host. Guest users do not have ability to change the Host's gameplay settings.

NOTE: the term “Guest” simply means all other users who join a Host's game. It is NOT the same as using “Guest Mode” to train on XS1. It does NOT mean you have been signed out of your profile.

IN-GAME PLAY

START POSITIONS – all players will spawn to a unique point to avoid a situation when they interfere with each other.

INTERACTIONS – players can't interfere (collide) with others in a direct way.

COINS – coins are common for all players, meaning if player A gets a particular coin, it will still be active for player B.

OBSTACLES – obstacles are sync among all players, meaning that when player A hits a particular obstacle, it becomes out-of-play and won't interfere with player B.



HOST GAME

Host Public Game

Host user creates public game by:

1. Open OxePlay
2. Choose desired game
3. Select **MultiPlayer** option
4. Select **Host A Game**
5. Select **Public**
6. Select **Group Race** for more than 2 players. Select **1:1** for 2 player competition
7. Select **Track**
8. Select **Level**
9. Click **Next**
10. Wait for players to join
11. Click on **Start Game** or wait for game to start automatically
12. Play

JOIN GAME

Join Public Game

Host user joins public game by:

1. Open OxePlay
2. Select desired game
3. Select **MultiPlayer** option
4. Select **Find A Game**
5. Select **Level** (this is a filter of game difficulty. It will find game matches selected level only)
6. Click **Find Game**
7. When game found, it'll join **Guest** session and wait
8. Wait for game to start automatically
9. Play

Host Private Game

Host user creates private game by:

1. Open OxePlay
2. Choose desired game
3. Select **MultiPlayer** option
4. Select **Host A Game**
5. Select **Private**
6. Select **Group Race** for more than 2 players. Select **1:1** for 2 player competition
7. Select **Track**
8. Select **Level**
9. Click **Next**
10. Game will generate **invitation code**. Copy and send Invitation Code to guest player(s)
11. Wait for guest player(s) to join
12. Click on **Start Game** or wait for game to start automatically
13. Play

Join Private Game

Host user joins private game by:

1. Open OxePlay
2. Select desired game
3. Select **MultiPlayer** option
4. Select **Join With Code**
5. Enter Code received from host
6. Click **Next**
7. View game session details and click **Join Session**
8. Wait for other players to join (if not 1:1 mode)
9. Wait for game to start automatically
10. Play

GAMING

MULTIPLAYER GAMING continued

IN-GAME MENU OPTIONS

MultiPlayer Mode does NOT have a restart option once game begins.

Available options are:

Respawn At Last Checkpoint – player spawns at last checkpoint with restoring health.

Exit Game – return back to the main menu.

Gameplay continues and does NOT pause when a player opens In-Game Menu or selects an option.

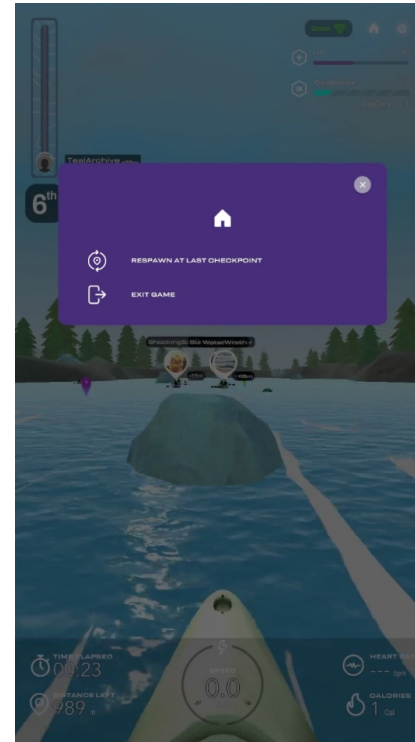

IN-GAME CONNECTION

A strong internet connection is essential to support a smooth gameplay.

A “connection” indicator will display quality of internet connection, providing 1 of 4 indications: **Good** | **Intermediate** | **Bad** | **Critical**

If the connection level becomes critical, the game will be unplayable and a “connection lost” message will appear.

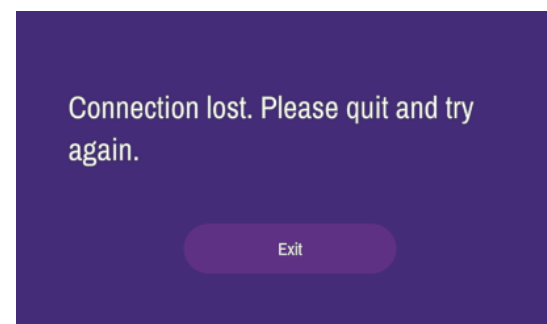

END GAME SUMMARY

All Players Reach Finish Line

When the game ends with all players passing the finish line, the Game Summary page will display all players listed with their finishing time.

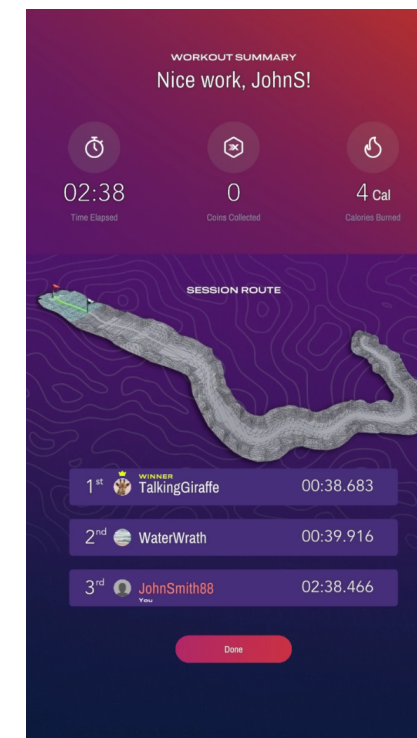

Player Leaves Track Early

If you reach the finish line and decide to exit the track while game is still active (at least 1 other player still competing to reach finish line), the Game Summary page will still display all players but ONLY known finishing times will be listed. See example of unknown time below.

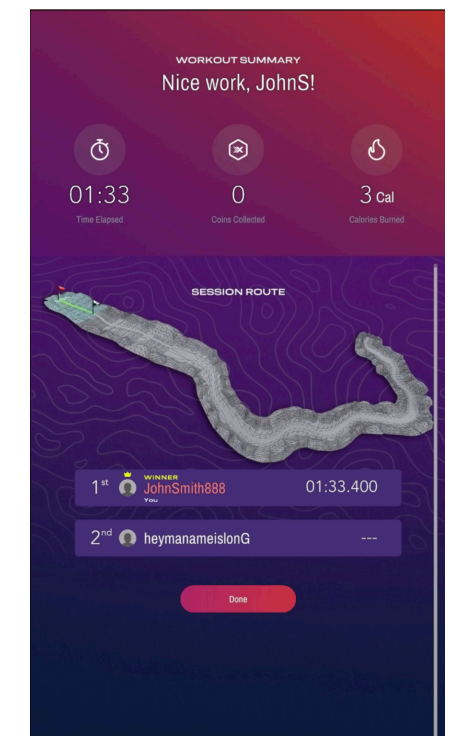



APPENDIX

IMPORTANT SAFETY INFORMATION

Please read all instructions, safety information, and warnings before using your OxeFit XS1. It is the responsibility of the owner to ensure that all XS1 users are aware of warnings, precautions, and safety requirements. Failure to follow instructions and safety precautions in this manual can result in serious injury or death.

Improper use of this equipment may result in injury or death. OxeFit is not responsible for injury, accidents, or damage caused by misuse of the equipment.

The OxeFit XS1 is not intended to diagnose, treat, cure, or prevent medical disorders or any conditions. Consult with your medical provider before starting a new workout plan.

Injuries may result if exercising improperly or excessively. It is recommended that all individuals consult a medical provider prior to commencing an exercise program. If at any time during exercise activities you feel faint, dizzy, or experience pain, stop exercising immediately and consult a physician.

Keep loose clothing, shoelaces, long hair, and accessories away from moving parts when the equipment is in use. Keep all observers, especially children and pets, away from moving cables and pulleys. Ensure others do not touch the machine when in use.

The XS1 is designed for the use of individuals aged 18 and up. Keep those under the age of 16 away from the machine. If approved in advance by a physician, those aged 16 – 18 may use the XS1 under direct adult supervision. An adult should review all safety instructions with the minor prior to use. The XS1 contains parts, components, and functions that can cause severe injury or death. You are responsible for the safety of any children and other persons you allow to use your XS1.

Be cautious when stepping onto and off of the platform. Please wear appropriate non-slip footwear. DO NOT dismount from equipment while any of the cables are loaded. Press the UNLOAD button to stop tension on cables.

Use reasonable care and safety precautions at all times while using the XS1, including resting, hydrating, and modifying any exercise as needed.

Ensure safety by checking for wear and damage regularly. Perform regular care and maintenance for optimal performance and longevity of the device. Discontinue use and contact OxeFit if the device is making unusual noises. Always unplug the device before cleaning.

Changes or modifications to this device that are not approved by OxeFit may void the warranty. DO NOT attempt to repair the XS1 on your own since this could affect its operation. Please contact OxeFit immediately for repairs.

Never use any accessories or equipment other than ones provided or approved by OxeFit. This includes dumbbells, weight plates, bands, chains, bars, or other means to increase the resistance force.

The XS1 is for indoor use only. DO NOT store the device outdoors, near water, or at high humidity levels. Metrics on the screen may be inaccurate and should be used as a reference only.

INSPECT XS1 BEFORE USE

Before using the device, familiarize yourself with the XS1 by reviewing each part to ensure it is in safe operating conditions.

- Adjustable Height Rack Hook (2)
- Slide Connection and Cable (2)
- Deck Connection and Cable (2)
- Foldable Deck
- Deck Handle
- Speaker (2)
- 32" Touchscreen
- Force Plate
- Microphone

*(2) Located on both right and left side of the XS1

DO NOT use the device if it is damaged or contains worn or broken parts. Use only replacement parts supplied by OxeFit.

NOTICES

This device is designed to comply with Part 15 of the FCC Rules. Operation is subject to the following two conditions:

(1) This device may not cause harmful interference, and (2) this device must accept any interference received, including interference that may cause undesired operation.

Contains:
FCC ID: SH6MDBT42Q
Contains:
IC ID: 8017A-MDBT42Q

USER REQUIREMENTS

Minimum Height: 4' 2"

Weight Range: 105 – 300 lbs / 48 – 136 kg

Minimum Age: 18 years

INSTALLATION REQUIREMENTS

ENVIRONMENT

Due to the sensitivity of the electronics, the XS1 system must be installed in a climate-controlled environment that meets the conditions specified below. The XS1 cannot be installed outdoors and the warranty does not cover devices that are placed outdoors or in locations that do not comply with OxeFit's location and operating environment requirements.

Operating Relative Humidity (RH)	20% to 70% non-condensing
Operating Temperature	50°F to 85°F (10°C to 30°C)
Storage Temperature	-13°F to 113°F (-25°C to 45°C)

LOCATION PLACEMENT

The XS1 requires at least 4 inches of clearance space on all sides (including behind it). The entire setup space should be at least 6' x 8.5'.

ELECTRICAL OUTLET

The XS1 requires a standard (120 VAC, 60 Hz), grounded, three-pronged outlet. If your XS1 requires an extension cord, ensure it is rated for at least 12A. Failure to provide these electrical requirements may void your warranty.

INTERNET

The XS1 requires a strong, continuous connection to wireless internet and operates best when connected to a 5GHz WiFi network.

WiFi connection requires a minimum download speed of 15 MBs and a minimum upload speed of 5 MBs, but higher speeds are recommended.

The XS1 only supports WPA2 encryption. We do not recommend the use of WiFi extenders as these devices can result in significantly slower internet speeds. If the WiFi signal is not strong in the planned XS1 location, we recommend the use of a mesh network to improve the coverage. The XS1 does not support the use of Eero routers.

See support article for more information and troubleshooting: [XS1 WiFi Connect & Troubleshooting](#)

FLOOR SPECIFICATIONS

Floor must be level. Hard surface floors are best. Gym mats and carpets are not recommended.

MAINTENANCE & CARE

QUICK REFERENCE NOTES

DO NOT have opened beverages on or near the XS1.
DO NOT use cleaners that contain solvents, alcohol, or abrasives.
Always shut down and unplug the XS1 before cleaning.

MAINTAIN LABELS & NAMEPLATES

Do not remove labels for any reason. Labels contain important information. If unreadable or missing, contact OxeFit for a replacement.

MAINTAIN ALL EQUIPMENT

Preventative maintenance is crucial to maintaining the function and safety of this equipment as well as keeping the equipment in safe operating condition. Failure to conduct preventative maintenance may cause the equipment to operate in a hazardous manner. Equipment needs to be inspected and maintained at regular intervals. For further questions, please contact support@oxefit.com

CLEANING

Keeping your XS1 clean is essential for ensuring proper operating conditions. Proper care and cleaning will extend the life of your equipment and reduce premature aging and wear.

Barbell should be wiped down after each use and cleaned daily with a mild soap and water mix or an approved antibacterial cleaner.

Hand grips should be cleaned daily with a mild soap and water mix or a non-abrasive, gentle antibacterial cleaner.

The padded upholstery of the strength bench and the multifunction bench should be cleaned after each use with a mild soap and water mix or non-abrasive, gentle antibacterial cleaner.

The main frame should be cleaned weekly with a mild soap and water mix or a gentle antibacterial cleaner, using a damp cloth to remove all dust and accumulated contaminants.

Gently wipe the touchscreen with a clean, soft, and dry cloth.

PREVENTATIVE

Preventative maintenance is crucial to maintaining the device's functionality and safety. Visual inspections of your XS1 will ensure a safe environment and promote awareness of any potential issues that may require maintenance prior to equipment failure. Contact OxeFit Support immediately for replacement parts.

DAILY

- Slide Handles—Verify that the slide handles can be raised and lowered smoothly. As the handles move, listen for unusual sounds like squeaks and grinding sounds. Report any abnormalities to support immediately.
- Carabiners—Inspect carabiners to verify that the latches are working properly and the handles are damage-free.

WEEKLY

- Cables—Inspect all cables for any signs of damage, including fraying, abrasion, twisting, and other signs of wear. **NOTE:** Over time, general signs of cable wear is normal due to rubbing on the pulleys.

MONTHLY

- Accessories—Inspect all accessories for wear or damage and replace as needed.
- Upholstery—Inspect upholstery for wear or damage and replace as needed.
- Pulleys—Inspect pulleys for integrity, cracking, or rubbing leading to excessive wear. Any incidents of wear should elicit immediate replacement of the damaged pulley.

If you notice any signs of issues or abnormalities, discontinue using the XS1 and contact support@oxefit.com immediately.

Keep this user manual for future reference.

SOFTWARE UPDATES

The XS1 will regularly check for software updates and will notify you when one is available.

- If the screen is unlocked when your device receives a new update, the notification will appear as an icon in the toolbar at the top of your screen.
- If the screen is locked when your device receives a new update, the notification will appear in the middle of your screen upon unlocking.
- If your device is powered off when a new update becomes available, it may take several minutes upon powering on for it to receive and notify you of the update.

To install a new software update, simply follow the notification prompts on your screen. Your device will initiate the process and may reboot to complete the installation.

Most software updates will be ready within a few minutes, and your device may reboot automatically to complete the installation process.

If your device encounters an error during the installation process, it will display an Update Failed message on the screen to inform you of the failed attempt. If this occurs, check your internet connection and re-initiate the installation process. If the update fails a second time, either power your device off and back on again or return to it in a few hours to re-attempt. If the error persists, please contact support@oxefit.com.

To see which software version your device is currently running, use the toolbar in the top right corner of the screen to access the device **Settings** → **About Your XS1** → **Software Version**.

WARRANTY

At OxeFit, we stand by our superior quality and product design. As a valued member of our community, your satisfaction is our priority. We offer a full one (1) year limited warranty that covers the use of OxeFit fitness equipment, such as the XP1 or XS1 (collectively, the “Product”). Specific exclusions apply, as described in the Limited Warranty. The Limited Warranty gives you specific legal rights, and you may also have other rights, which vary from State to State. Please note that we reserve the right to change the Limited Warranty at any time.

If, for any reason, you are having any problems with your Product, please reference our support number and email listed at the bottom of this section so we can help. The following parts and components of the Product are warranted as described:

- HD Touchscreen—Twelve (12) Month Warranty: OxeFit warrants the touchscreen against defects in workman-ship and materials for a period of twelve (12) months from the date of original delivery to you.
- Frame—Thirty-six (36) Month Warranty: OxeFit warrants the Product platform frame (excluding any moving parts attached to the structural frame) against defects for a period of three (3) years from the date of original delivery to you.
- Moving and Electrical Components—Twelve (12) Month Warranty: OxeFit warrants the components and all original parts of the Product against defects for a period of twelve (12) months from the date of original delivery to you.
- Labor—Twelve (12) Month Warranty: OxeFit will cover the labor cost for reasonable repair or replacement of components and equipment that OxeFit determines to be defective for a period of twelve (12) months from the date of original delivery to you. In the event OxeFit determines that repair is not possible, OxeFit will replace your equipment.

EXCLUSIONS & LIMITATIONS

Who is covered?

The original purchaser of the Product is covered by the Limited Warranty (including, if applicable, the use of OxeFit parts and accessories) and is not transferable or assignable to any other party.

What is covered?

OxeFit covers manufacturer’s defects that arise in the Product or warranted components within the applicable Limited Warranty time period described in the Warranty section. Any replacement components are warranted for the remainder of the original existing Limited Warranty period. Under the Limited Warranty, OxeFit reserves the right to substitute material of equal quality if identical materials are not available at the time of service. The replacement of the product under the terms of the Limited Warranty in no way extends the applicable warranty period. In the event repair is not possible, OxeFit will replace your equipment.

What is NOT covered?

The Limited Warranty does not cover any damages due to (i) transportation of any kind after installation; (ii) storage; (iii) improper use; (iv) failure to follow the product instructions (including the safety instructions) or to perform any preventative maintenance; (v) modifications; (vi) unauthorized repair; or (vii) external causes such as accidents, abuse, environmental damages, or other actions or events beyond our reasonable control. The Limited Warranty also does not apply to damages due to normal wear and tear. You must maintain the Product, including the cables and other components, by inspecting your Product regularly for any damage, loose parts, or other signs of wear and tear that could cause breakdowns or component failures.

OxeFit does not warrant that the operation of the Product will be uninterrupted or error-free concerning software sold or embedded within the device. The annual software subscription renewal covers software, portal, and application support and assistance. Please contact us through our support request, number, or email.

HOW TO OBTAIN WARRANTY SERVICE

To be eligible for service under this Limited Warranty, you must contact the OxeFit Support team. If you discover any nonconformity or defect, contact the OxeFit Support team immediately. You will need to provide OxeFit with the serial number of your XP1 or XS1 and the dated receipt or other proof of purchase indicating the date purchased. You must make claims within the specified warranty period.

OXECARE

Scan QR Code below to view the details of OxeCare, the extended warranty for XS1 and XP1.



LEARN & SUPPORT

LEARN MORE

Learn more about fitness, training, and XS1 best practices via the OxeLearn Blog on our website. Scan QR Code to access.



GET SUPPORT

Visit the Support Center on our website for troubleshooting, additional resources, and to request personal assistance. Scan QR Code to access.

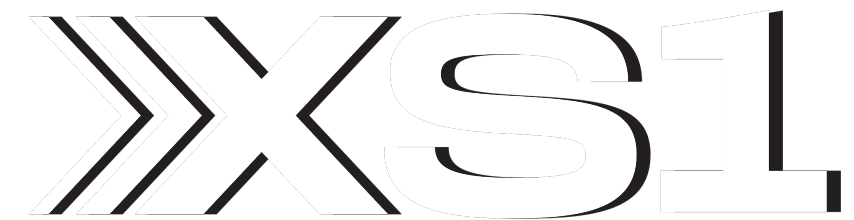



www.OxeFit.com

© OxeFit, Inc. All Rights Reserved. 2025